



PECO

50 CUBIC FOOT TRAILER

OWNERS MANUAL



MODEL #7950-04 & 10950

Your new PECO Vac has been engineered and manufactured to PECO'S high standards for safety, quality, dependability, and ease of operations.

SAVE THIS MANUAL FOR FUTURE REFERENCE

ASSEMBLY INSTRUCTIONS

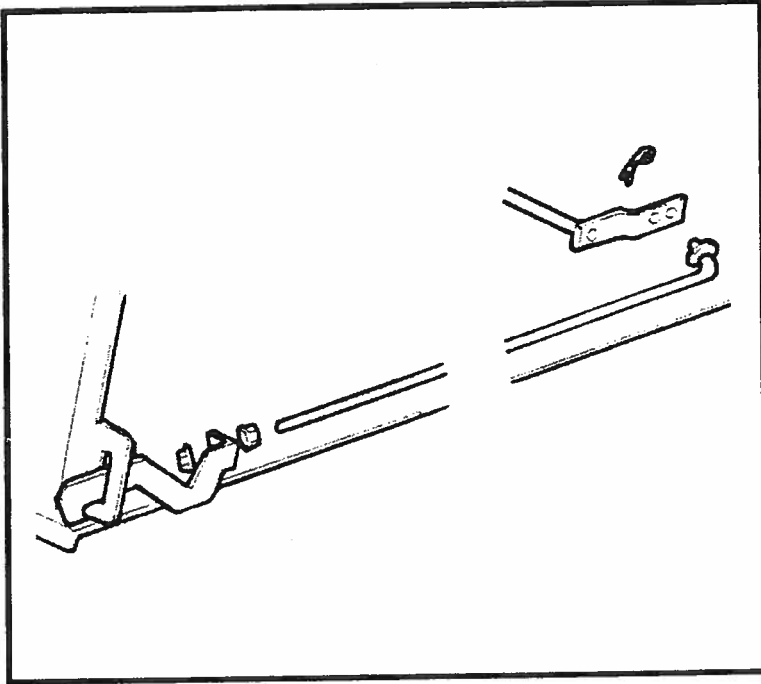

14. Loosely attach the thread end of the latch rod to the latch hook with (1) 1/2"-13 flange nut. Attach the bent end to the latch rod assembly with a hair pin. Adjust the latch to pull the door in tightly. Attach the rubber grip to the latch handle.

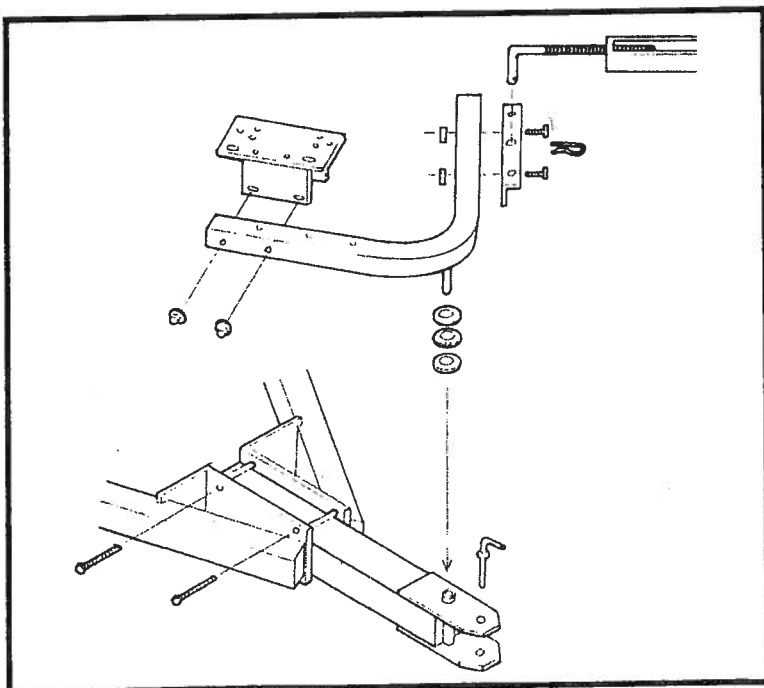

15. Attach the tongue assembly to the base frame with (3) 3/8"-16 x 2-1/4" hex bolts and (3) 3/8"-16 flange nuts. Install the engine support arm with (2) 1" flat steel washers and (1) 1" bronze thrust washer. Attach the engine stay plate to the support arm with (2) 3/8"-16 x 3" hex bolts and (2) 3/8"-16 flange nuts. Attach the ball clevis assembly to the engine stay plate with a hair pin, (as shown) attach the other end to the mower's axle. Attach the engine mount arm to the engine support arm with (2) 3/8"-16 x 3" hex bolts and (2) 3/8"-16 flange nuts.

NOTE: Engine mount is for both left hand and right hand discharge mower decks.

PECO LIMITED WARRANTY FOR NEW PRODUCTS

A. WHAT IS WARRANTED?

Peco extends the following warranties to the original purchaser of each new Peco consumer product subject to the following limitations.

1. PRODUCT WARRANTY: Any part of any consumer product, which is defective in material or workmanship as delivered to the purchaser will be repaired or replaced, as Peco elects, without charge for parts or labor, if the defect appears within 12 months from the date of delivery of the product to the original purchaser. **ALL DEFECTIVE PARTS MUST BE RETURNED TO PECO FOR INSPECTION TO DETERMINE VALIDITY OF WARRANTY CLAIMS.**

Freight and mailing will be borne by the customer.

2. PARTS REPLACED DURING WARRANTY: Any new Peco part which is furnished in performance of this warranty and is defective in material or workmanship as delivered to the purchaser will be repaired or replaced, as Peco elects, without charge if the defect appears within 90 days from the date of installation of such part or before the expiration of the original warranty period, whichever is later.

B. SECURING WARRANTY ADJUSTMENTS.

Damaged or broken parts other than engines or batteries, must be returned to Peco, Inc., P.O. Box 1197, Arden, NC 28704 before any warranty adjustment, can be authorized. At the time of requesting warranty adjustment, the purchaser must present evidence of the date of delivery of the product. The purchaser shall pay any charge for the product to and from Arden, NC.

C. ITEMS NOT COVERED BY PECO WARRANTY.

Engines and batteries attached to PECO products are covered under a separate warranty by the respective manufacturer.

D. UNAPPROVED ALTERATION OR MODIFICATION.

All obligations of Peco, Inc. under this warranty shall be terminated if products are altered or modified in ways not approved by Peco Inc.

E. ACCIDENTS AND NORMAL MAINTENANCE.

The warranty covers only defective material and workmanship. It does not cover depreciation or damage caused by normal wear, accident, improper use or abuse of products. The cost of normal maintenance and normal replacement of service items such as belts, cutting blades, hoses, etc., which are not defective shall be paid for by the purchaser.

F. NO REPRESENTATIONS ADDITIONAL WARRANTIES, DISCLAIMER.

Neither Peco Inc. nor any company affiliated with it makes any warranties, representations or promises as to the quality of performance of its products other than those set forth herein. Except as described above, Peco Inc. makes no other warranties **AND SPECIFICALLY DISCLAIMS ANY AND ALL IMPLIED WARRANTIES OF FITNESS AND MERCHANTABILITY.**

G. ANY MACHINE USED FOR RENTAL OR COMMERCIAL PURPOSES ARE GUARENTEED FOR 45 DAYS FROM DATE OF ORIGINAL SALE ONLY.

H. REMEDIED EXCLUSIVE.

The only remedies the purchaser has in connection with the breach or performance of any warranty on Peco Inc. consumer products are set forth above. In no event will Peco be liable for special incidental or consequential damages.

1. NO SERVICE CENTER WARRANTY.

The selling Service Center makes no warranty on his own on any item warranted by Peco Inc. unless he delivers to purchaser a separate written warranty certificate specifically warranting the item. The dealer has no authority to make any representation or promise on behalf of Peco or to modify the terms of this warranty in any way.

NORMAL CARE

Your Lawn Vac was designed and built to provide years of service with only minor care. Certain tasks, however, must be performed to keep it in good operating condition and to avoid costly repairs. This section describes procedures for the necessary care of your lawn vac.

SCHEDULED CARE

A schedule for the routine care of the vacuum collector is provided. Some of the schedule requirements are based on operating hours. For this reason, it will be necessary to determine or estimate total operating time. This is easily accomplished if your tractor is equipped with an hour meter, if not, you can determine normal times for regular jobs. Multiply these normal times by the number of times you perform these jobs and add any unusual operating time or estimate the total time.

SCHEDULE	CARE REQUIRED
Before each use	Check engine oil Check all hose connections
After each use	Clean collector hoses and engine of all grass and dirt
Every 10 hours	Check to be sure all nuts, bolts, bolts, pins etc. are present and secure.

STORAGE

Never store your Lawn Vac with a full or partially full container. Decaying grass and leaves may constitute a fire hazard if left to long. Never leave your Vac exposed to the elements. Although the metal parts are protected with quality paint, the engine and other unprotected parts may deteriorate if left exposed to rain or snow.

PRE-START CHECKLIST

The steps listed below should be performed before each use of the vacuum collector.

1. Be sure you are familiar with the safety precautions, controls, and operation of the mower. Read your mower owner's manual carefully!
2. Check the mower and vacuum collector to be sure they are properly installed and to be sure all nuts, bolts, and pins are secure.

OPERATION OF LAWN VAC AND MOWER

After you have performed the "Pre-start checklist", begin operation by starting your fueled lawn vac engine and set it to run at 3/4 open throttle. Next, start your mower according to its instructions.

For average dry conditions, set the mower's engine throttle about 3/4 open and operate the mower at normal ground speed. Under damp conditions or when collecting thick heavy material, run the vac engine at full throttle and use low mower ground speed.

In extremely tall or heavy grass it may be necessary to cut only half the width of the mower deck or raise the cutting height on the first pass to prevent clogging hoses. Check the hoses and the blower housing periodically for blockage.

OPERATION ON SLOPES

Always use caution when operating the mower on slopes. Front wheel weights may be required to offset the weight of the vacuum collector behind the mower. Even with wheel weights installed, avoid fast starts and adjust the mower's ground speed to fit the conditions.

SAFETY

OUTDOOR POWER EQUIPMENT INSTITUTE **RECOMMENDATIONS**

WARNING TO PURCHASERS OF INTERNAL COMBUSTION ENGINE EQUIPPED MACHINERY OR DEVICES IN THE STATE OF CALIFORNIA:

The equipment which you have purchased does not have a spark arrester muffler. If this equipment is to be used on any forest covered and brush covered land or grass covered unimproved land in the state of California, the law requires that a spark arrester muffler be installed and be in effective working order. The spark arrester must be attached to the exhaust system and comply with Section 4442 of the California Public Resources Code.

1. Read the owner's manual carefully and familiarize yourself with the proper use of your attachment. Do not allow anyone who is not acquainted with the Safety Instructions use your attachment.
2. Know the controls and how to stop quickly. **READ THE OWNERS MANUAL.**
3. Do not allow children to operate the vehicle. Do not allow adults to operate it without proper instruction.
4. Be especially watchful of children and pets darting into the area while operating.
5. Keep your eyes and mind on your tractor while mowing or operating your attachment. Don't let others distract you.
6. Do not attempt to operate your tractor or mower when not in the driver's seat.
7. Always stop the Vac engine when emptying the container. This will prevent grass clippings or debris from being blown in your eyes.
8. Stop the tractor and vac engines and remove the spark plug wire before removing or replacing the hose, boot, blower cone, or performing maintenance.
9. Mow up and down the face of slopes (not steeper than 10 degrees); never across the face of the slope.
10. It is recommended that the container be kept only half full when negotiating any slopes. Start mowing on slopes when the container is empty.
11. Inspect you lawn and remove any foreign objects before mowing. Never deliberately run the across any foreign object.

! WARNING !

- * NEVER operate the mower unless the discharge guard and either the deflector assembly or the vacuum collector adapter are fastened securely in place.
- * To avoid serious injury, perform maintenance on the vacuum collector ONLY AFTER STOPPING THE TRACTOR ENGINE AND WAITING FOR ALL MOVING PARTS TO COME TO A COMPLETE STOP. Set the parking brake. Always remove the ignition key before beginning the maintenance.
- * Do not work around the mower deck or the blower housing area until you are certain that the mower blades and the blower fan have stopped rotating.
- * For your personal safety, ALWAYS mow UP and DOWN the face of slopes and NEVER across the face. NEVER attempt to mow excessively steep slopes and use caution when turning on any slope.

PARTS INFORMATION

Peco Lawn Vac Owners should record the name and telephone number of their tractor dealer/distributor. Our dealer/distributor will be happy to supply replacement parts, accessories, and do any service, or repairs to your lawn vac. For any reason your dealer/distributor is unable to service your lawn vac or supply replacement parts, contact Peco and include the following information:

Tractor Model: _____

Engine Size: _____

Peco Vac Serial Number: _____

Date of purchase: ____/____/____

Dealer/Distributor Name: _____

Dealer's/Distributor's: _____ State: _____ Zip: _____

Phone Number: _____

Address: Peco Inc.

100 AIRPORT RD

Arden, NC 28704

Phone #: (828) 684-1234 or Toll Free: (800) 438-5823

PECO WAND ATTACHMENT

Make your Peco Lawn Vac the total lawn grooming tool with the Peco Wand Attachment. Now you can clean all those hard to reach places such as under bushes, shrubs, flower gardens, and walkways.

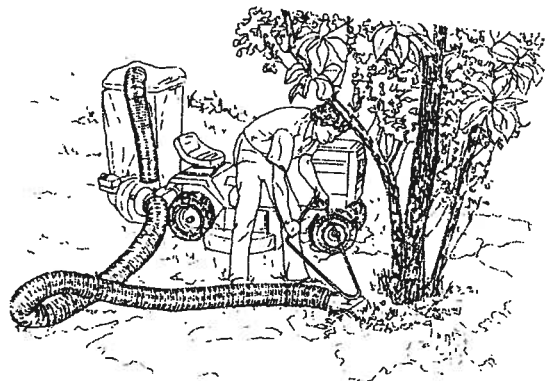

PECO

OUTDOOR POWER EQUIPMENT

Model Number

Serial Number

Arden, North Carolina 28704

PECO PARTS LIST

REF NO.	PART NO.	DESCRIPTION	QTY.
01	A0338	DOOR RAIL ASSEMBLIES	02
02	A0952	DOOR ASSEMBLY	01
03	C1189	SIDE PANELS	02
04	A0956	SCREEN FRAME ASSEMBLY	01
05	C1190	BOX TOP	01
06	A0341	PIVOT ROD ASSEMBLIES	02
07	A0372	DUMP HANDLE	01
08	C1191	BOX FRONT PANEL	01
09	E8004	INLET RING	01
10	J0527	3/4" D INLET SEAL	01
11	A0957	INLET ASSEMBLY	01
12	A1684	UPRIGHT ASSEMBLY	01
13	N/A	BOOT ASSEMBLY	01
14	A0850	BOOT CLAMP ASSEMBLY	01
15	J6011	5" - 6" HOSE CLAMPS	02
16	N/A	LOWER HOSE	01
17	A0159	BALL CLEVIS ASSEMBLY	01
18	A1330	AXLE CLEVIS ASSEMBLY	01
19	B2266	AXLE CLAMP BAR	01
20	B4319	ADJUSTING ROD	01
21	B2285	ENGINE STAY PLATE	01
22	006572	JACK STAND ASSEMBLY	01
23	B4141	JACK PIN	01
24	A0342	HITCH PIN ASSEMBLY	01
25	F2012	7" x 60" UPPER HOSE	01
26	J6006	7" - 8" HOSE CLAMPS	02
27	J0522	HANDLE GRIP	01
28	E6005	6" BLOWER CONE	01
29	K2145	BLOWER CONE BOLTS	02
30	D5003	10HP GAS ENGINE	01
	D9001	7HP DIESEL ENGINE	
31	E5007A	BLOWER HOUSING	01
	A0644	IMPELLER	01
32	A0395	BASE FRAME ASSEMBLY	01
33	A0242	ENGINE SUPPORT ARM ASSEMBLIES	03
34	K9706	STEEL 1" WASHERS	02
35	H1011	PNEUMATIC WHEELS	02
36	K0058	FLAT 5/8" WASHERS	02
37	K1393	5/8"-16 x 1-1/4" HEX BOLTS	02
39	C7001	LATCH BEARING BLOCK	04
40	A0467	LATCH ROD ASSEMBLIES	02
41	B4225	PIVOT	01
42	A0040	TILT BASE FRAME ASSEMBLY	01
43	A0365	LATCH RODS	02
44	B1418	LATCH HOOKS	02
45	B5277	DIAGONAL RAILS	02
46	A0051	VERTICAL RAIL ASSEMBLY (RIGHT)	01
47	A0050	VERTICAL RAIL ASSEMBLY (LEFT)	01
48	C1188	BOX BOTTOM	01
49	B2268	PIVOT ROD STRAPS	02
50	B2377	DOOR RAIL BACKER PLATES	04
51	A0380	TONGUE ASSEMBLY	01
52	A0243	ENGINE MOUNT ASSEMBLY	01

EXPLODED VIEW

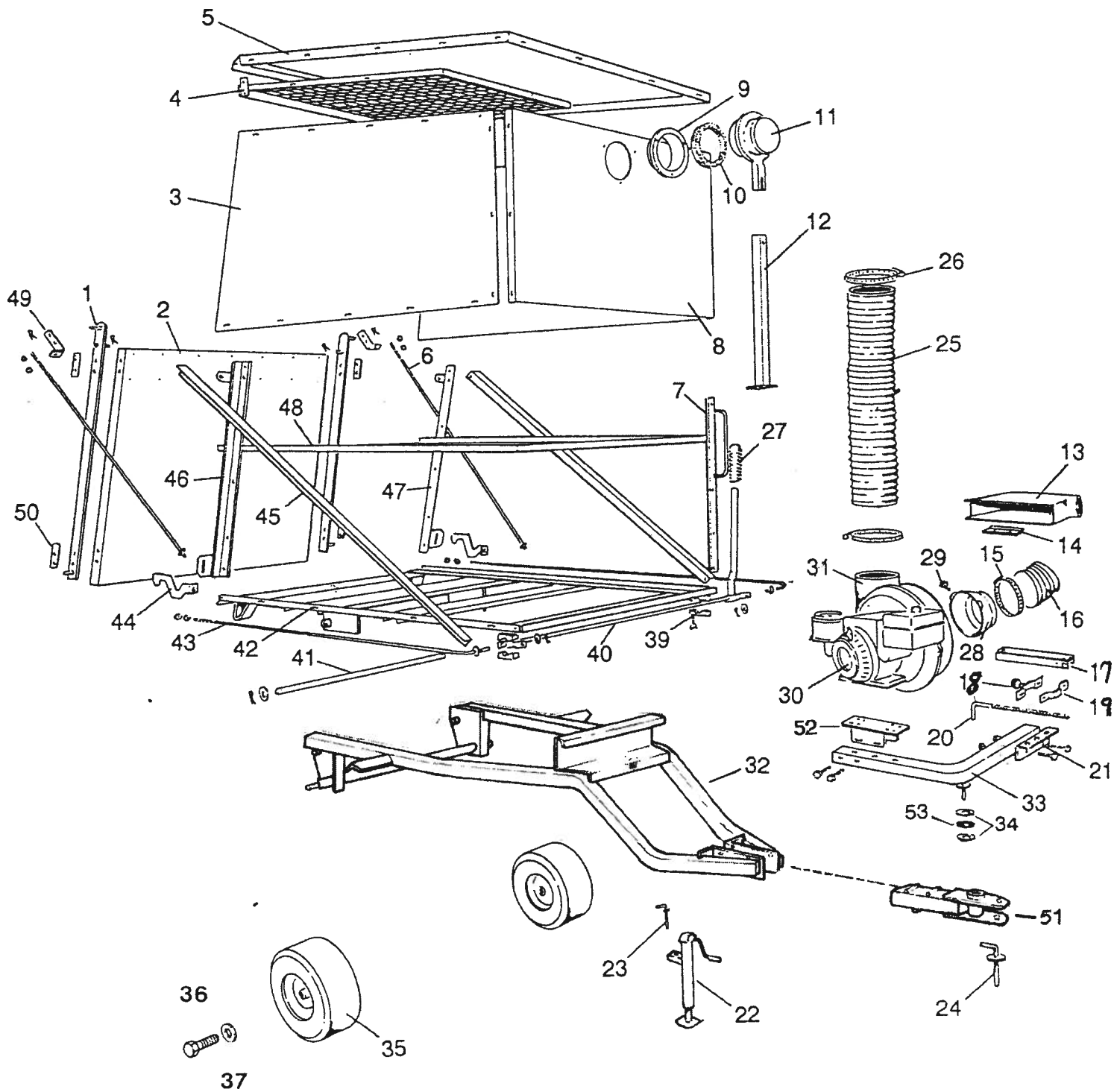

ASSEMBLY INSTRUCTIONS

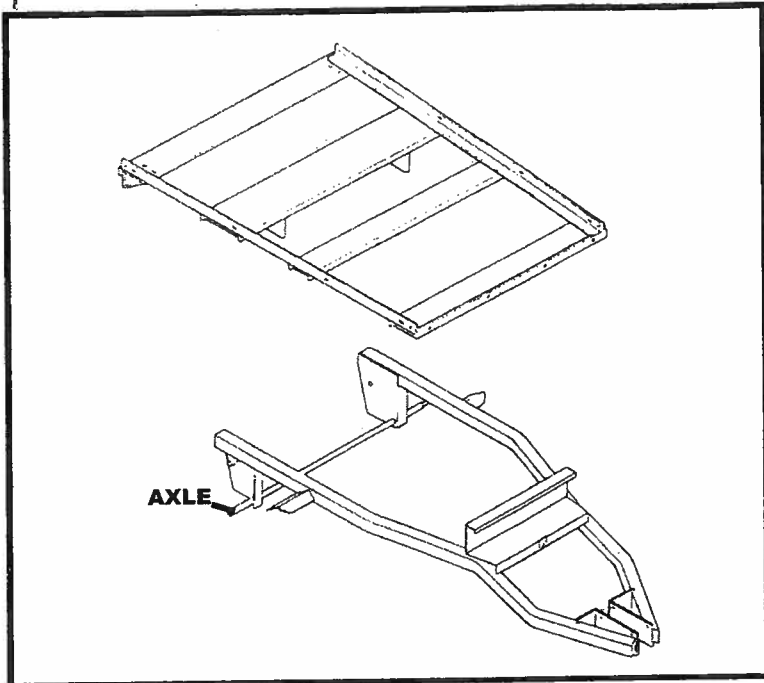

1. Install the tilt frame using the short axle with (1) 3/4" washer and (1) cotter pin on each side.

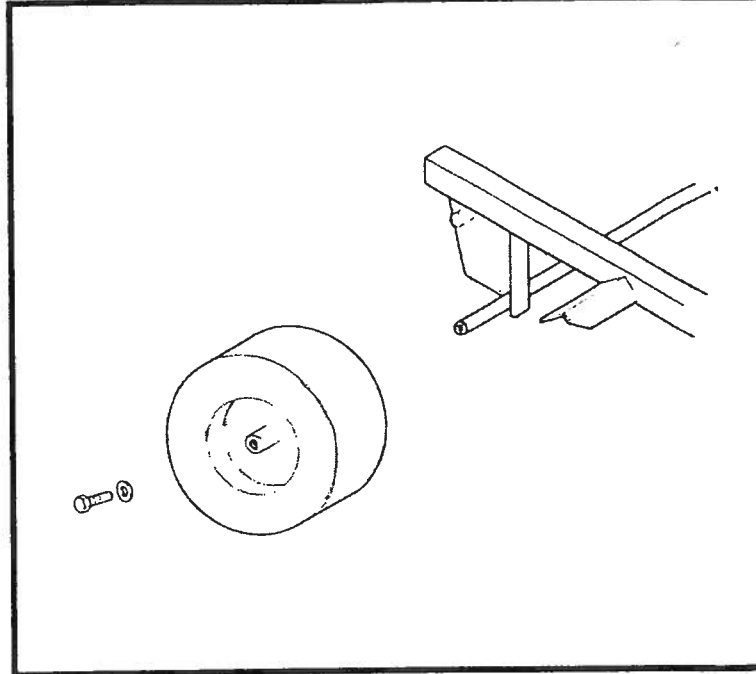

2. Lift the base frame up enough to place the wheels on to the ends of the axle. Secure the wheels with (1) 5/8" flat washer and (1) 5/8"-16 x 1-1/4" hex bolt.

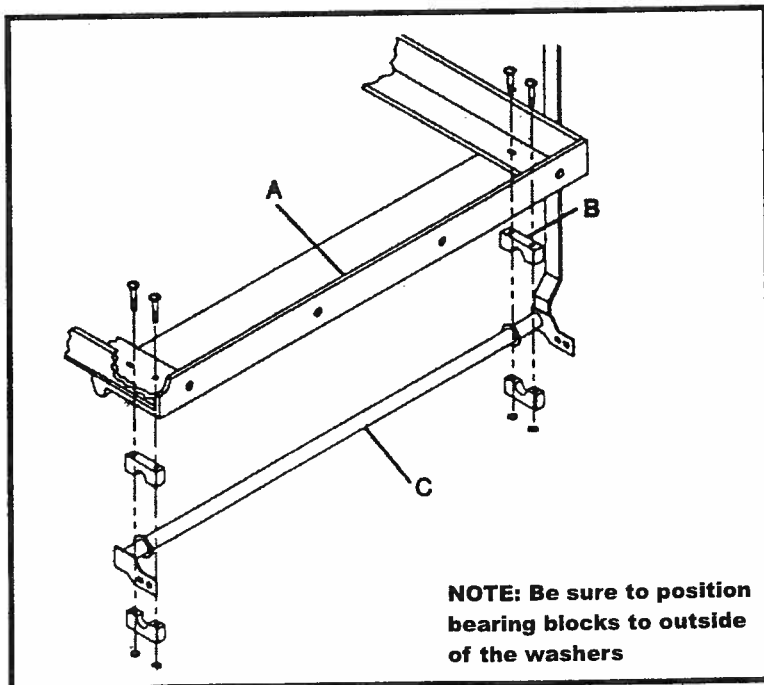

NOTE: Be sure to position bearing blocks to outside of the washers

3. To assemble the latch rod assembly insert (4) 3/8"-16 x 2" carriage bolts into the front cross support (A) and through the bearing blocks (B). Use the latch rod (C) to hold the assembly into place while securing the bearing blocks with (4)

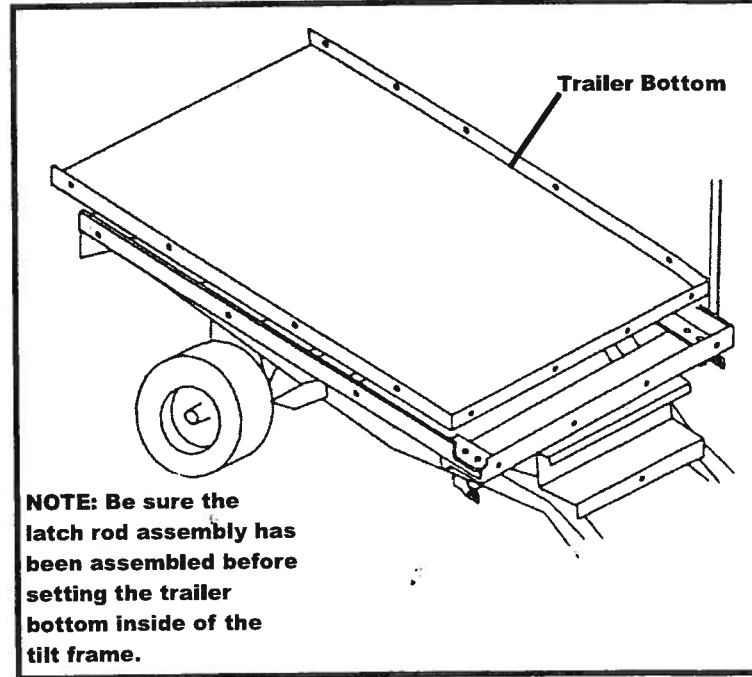

NOTE: Be sure the latch rod assembly has been assembled before setting the trailer bottom inside of the tilt frame.

4. Set the trailer bottom inside of the tilt frame.

ASSEMBLY INSTRUCTIONS

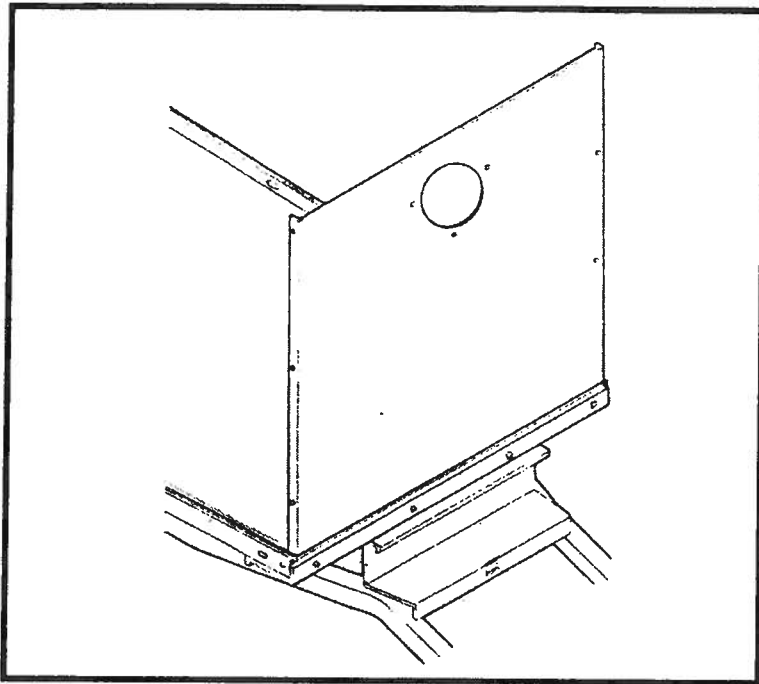

5. Loosely attach the front panel inside the trailer bottom with (4) 5/16"-18 x 3/4" carriage bolts and (4) flange nuts.

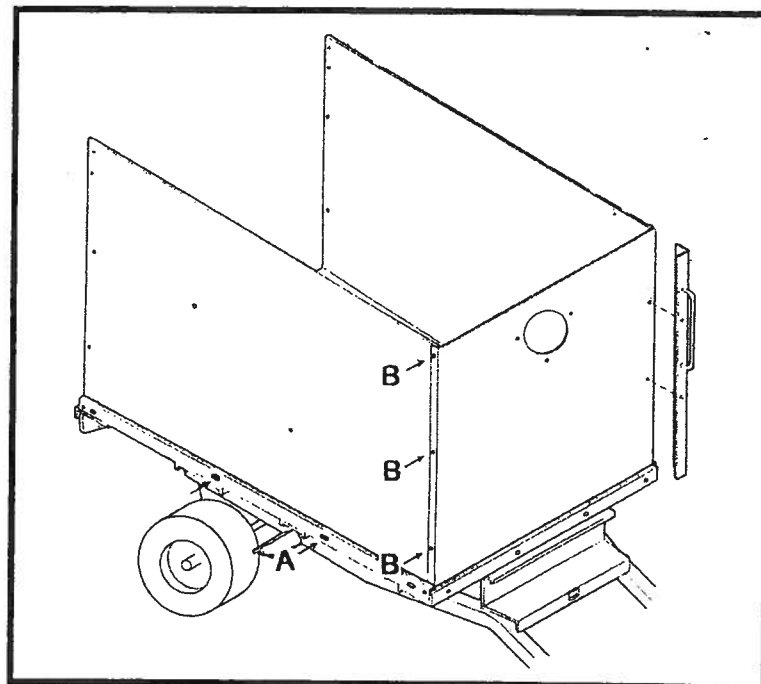

6. Loosely attach the side panels inside the trailer bottom and front panel with (3) 5/16"-18 x 3/4" carriage bolts and (3) 5/16"-18 flange nuts each side using holes (A). Use (3) 5/16"-18 x 3/4" carriage bolts and (3) 5/16"-18 flange nuts in holes (B). Leave the other holes open for attachments later. While securing the left panel, attach the dump handle to the corner of the front and left panels using the top two left panel bolts.

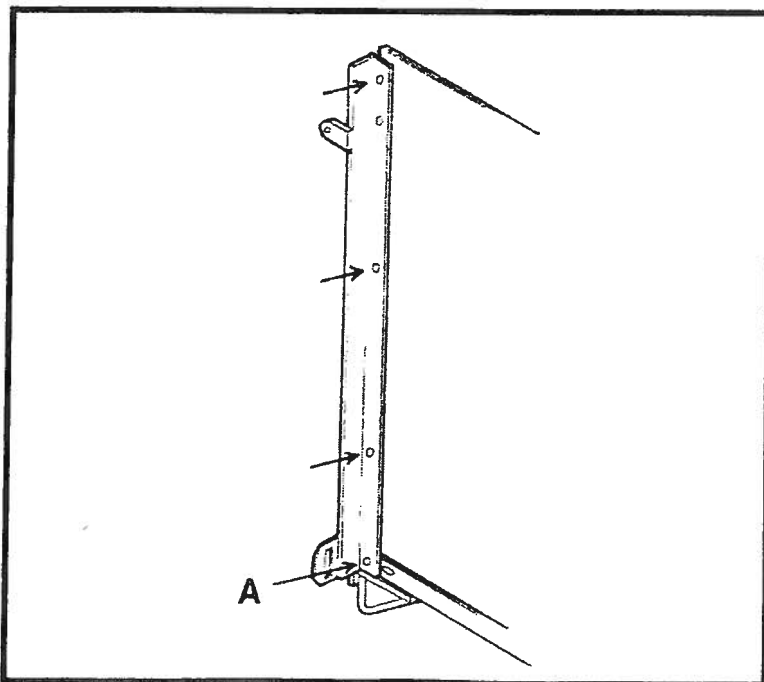

7. Loosely attach both vertical angle irons to the side panels with (4) 5/16"-18 X 3/4" carriage bolts and (4) 5/16"-18 flange nuts each using the holes shown. Attach to the tilt frame with (1) 5/16"-18 X 1-1/4" carriage bolt and (1) 5/16"-18 flange nut using hole (A). The edge of the aluminum must be flush with the angle iron or just behind it.

ASSEMBLY INSTRUCTIONS

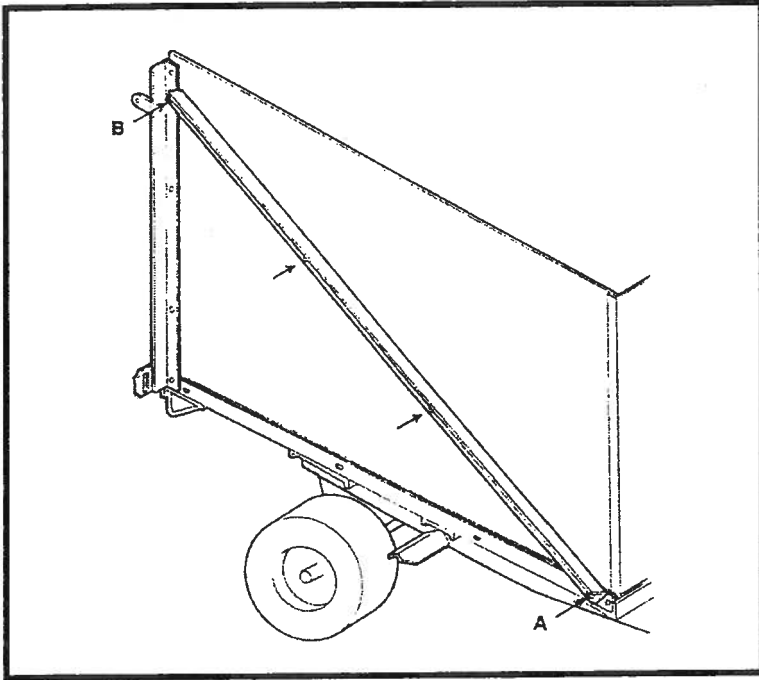

8. Loosely attach both diagonal angle irons to side panels with (2) 5/16"-18 x 3/4" carriage bolts and (2) 5/16"-18 flange nuts using holes shown (A). Bolt to tilt frame hole (B) and the vertical angle iron hole (C) with (2) 5/16"-18 x 1" carriage bolts and (2) 5/16"-18 flange nuts.

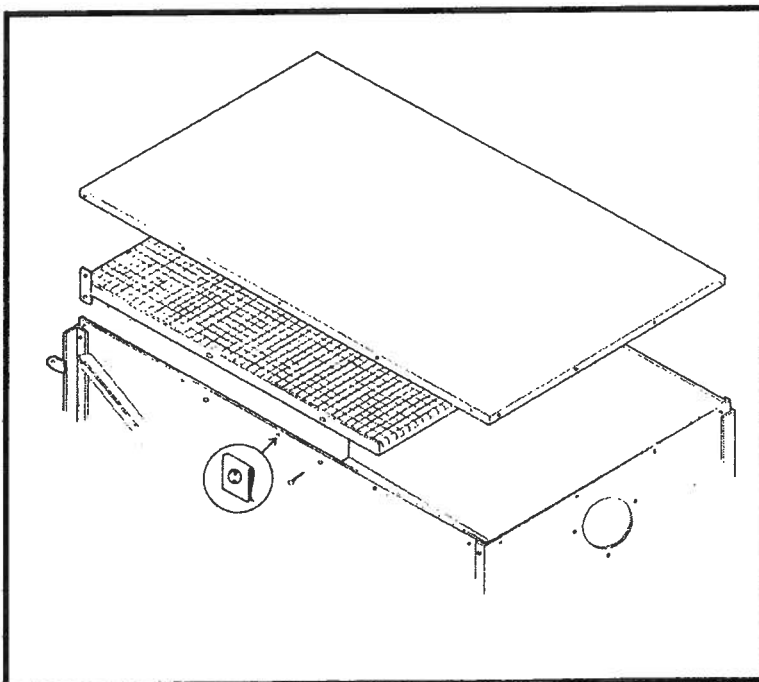

9. Loosely install screen frame to the vertical and diagonal angle irons using the two top bolts already installed. Attach to the side panels with (4) 1/4"-20 x 5/8" carriage bolts & (4) 1/4"-20 flange nuts. Attach (14) Tinnerman clips along the tops of the side and front panels. Use (14) Tinnerman screws to attach the top. Tighten all bolts.

ASSEMBLY INSTRUCTIONS

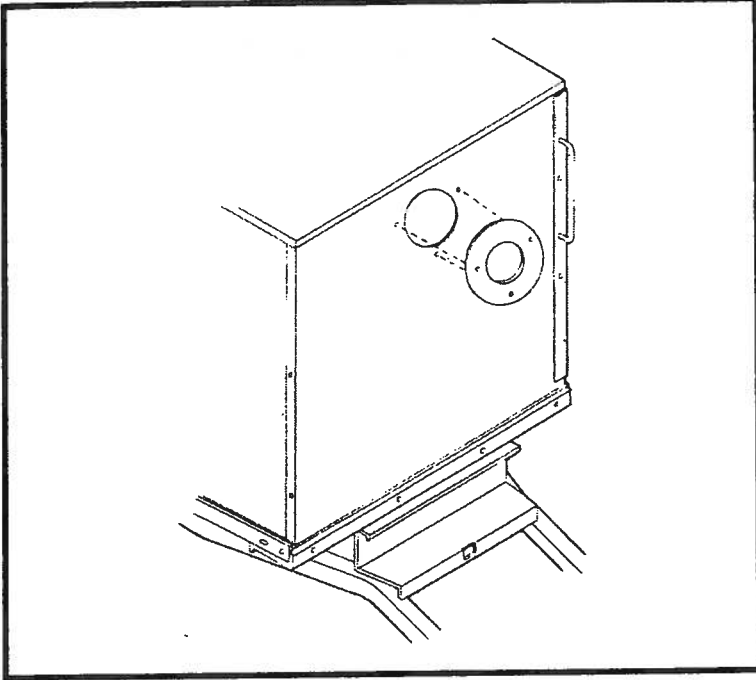

10. Secure the aluminum ring on the front panel (flange inward) with (3) Tinnerman screws and (3) Tinnerman clips.

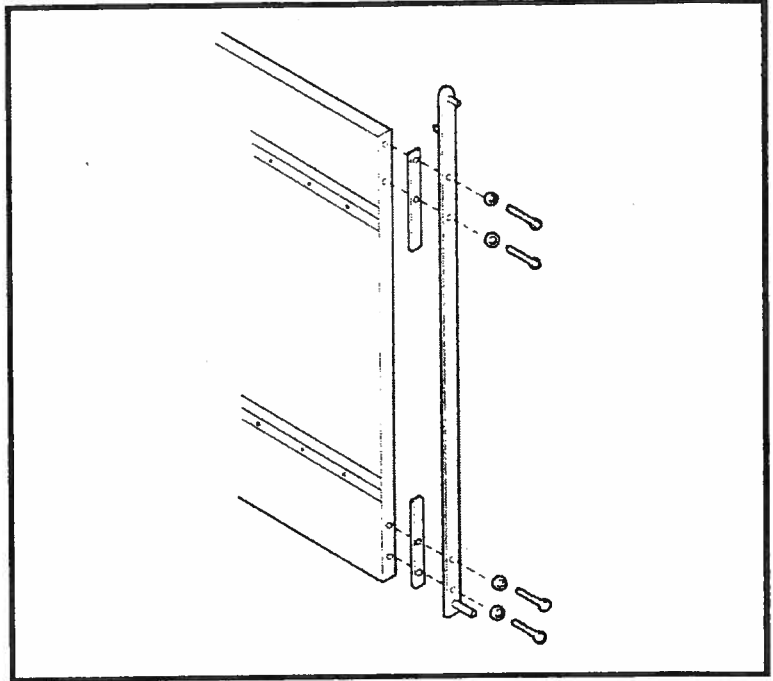

11. Very loosely attach both the hinge rails to the door using backup strips and 5/16" nuts and bolts.

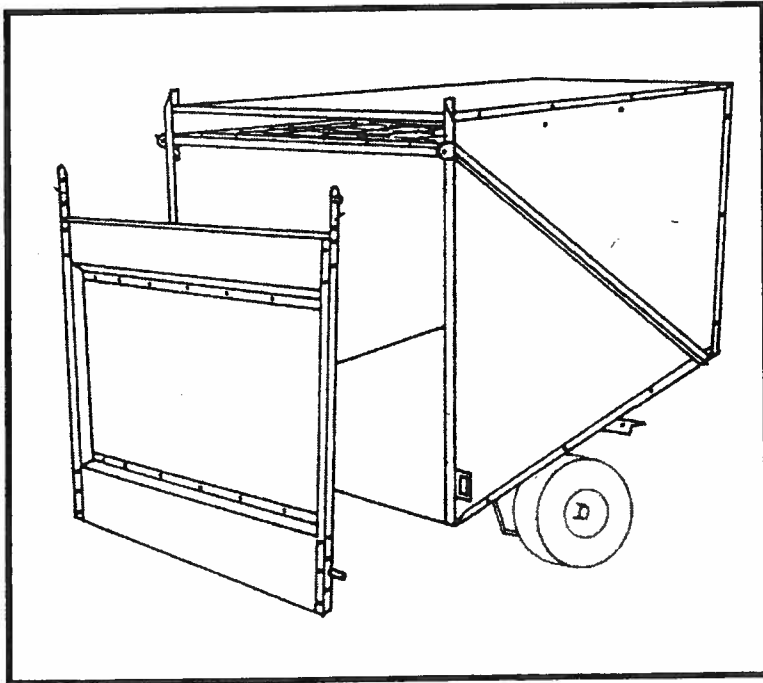

12. Spread open the door hinge rails and slide over the door hinge tabs on the vertical angle iron. Secure with a hair pin. Tighten all nuts and bolts.

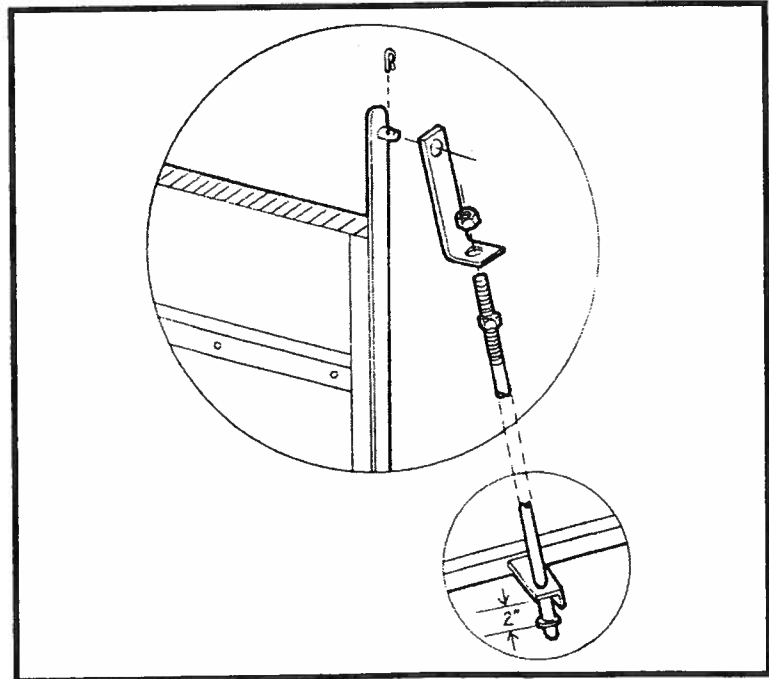

13. Slide the pivot rod through the angle support bracket on the side of the cross support. Attach to the pivot rod strap with 1/2"-13 flange nut. Attach the assembly to the door pin with a hair pin.

ASSEMBLY INSTRUCTIONS

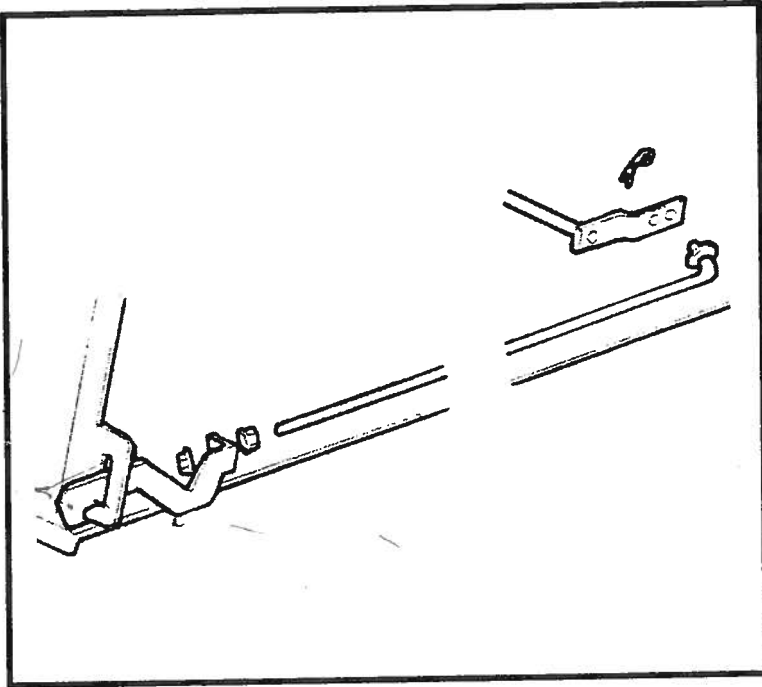

14. Loosely attach the thread end of the latch rod to the latch hook with (1) 1/2"-13 flange nut. Attach the bent end to the latch rod assembly with a hair pin. Adjust the latch to pull the door in tightly. Attach the rubber grip to the latch handle.

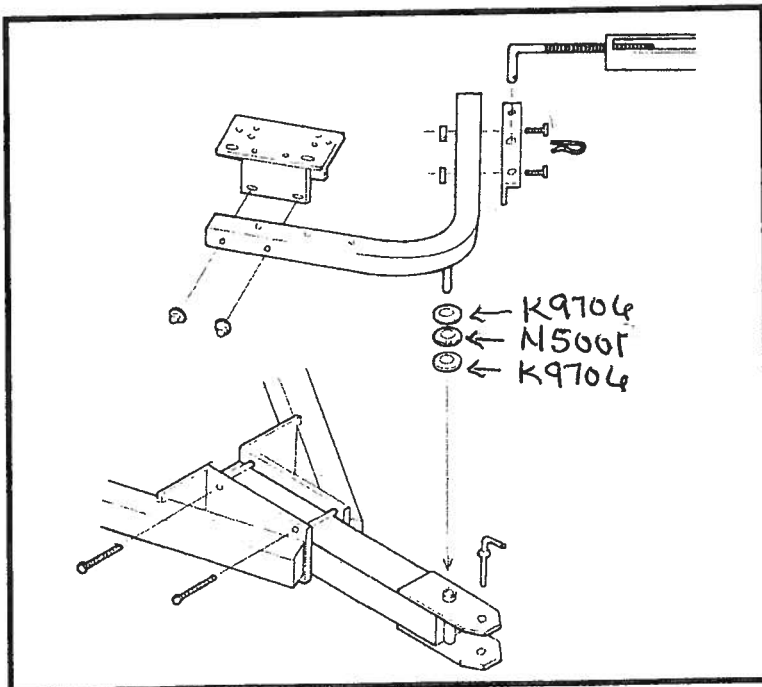

15. Attach the tongue assembly to the base frame with (3) 3/8"-16 x 2-1/4" hex bolts and (3) 3/8"-16 flange nuts. Install the engine support arm with (2) 1" flat steel washers and (1) 1" bronze thrust washer. Attach the engine stay plate to the support arm with (2) 3/8"-16 x 3" hex bolts and (2) 3/8"-16 flange nuts. Attach the ball clevis assembly to the engine stay plate with a hair pin, (as shown) attach the other end to the mower's axle. Attach the engine mount arm to the engine support arm with (2) 3/8"-16 x 3" hex bolts and (2) 3/8"-16 flange nuts.

NOTE: Engine mount is for both left hand and right hand discharge mower decks.

ASSEMBLY INSTRUCTIONS

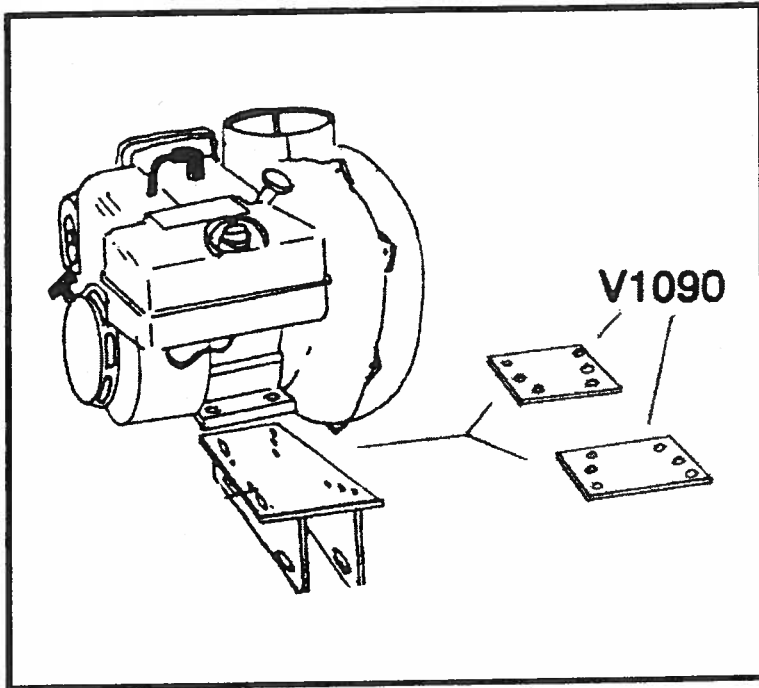

! SPECIAL INSTRUCTIONS !

Before mounting the engine in place the rubber shock absorbers (PN#V1190) onto the engine mount plate and align holes (should be sandwiched between the mount plate and the base of the engine.)

16. Secure the engine on the engine mount plate with (4) 5/16"-18 X 2" hex bolts and (4) 5/16" flange nuts. (For diesel engine use (4) 3/8"-16 X 2" hex bolts & (4) 3/8" flange nuts.)

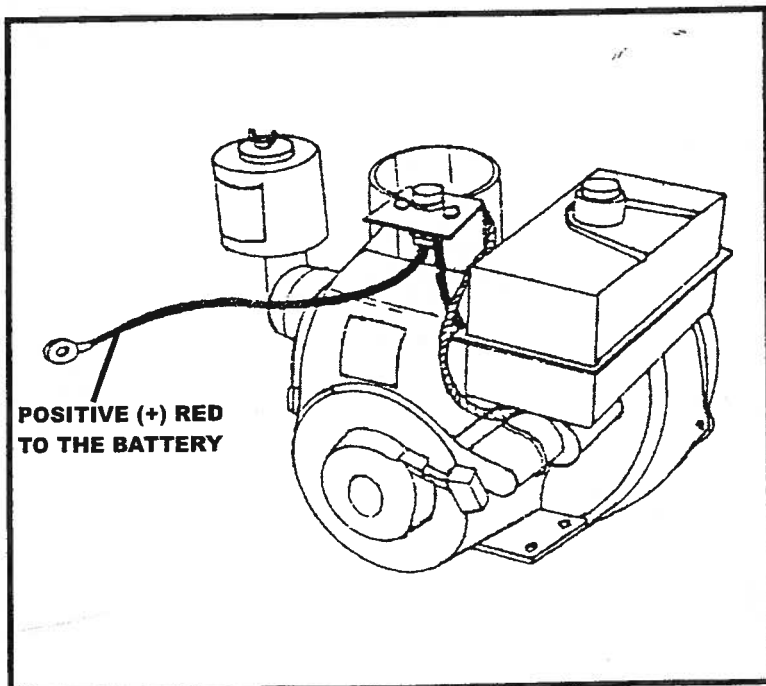

17. Route the positive (+) cable from the electric engine controls to the positive (+) terminal on the tractor. **NOTE: Unit is grounded through the hitch mount.**

! CAUTION !

Failure to keep the lock ring and muffler nipple may result in engine damage. Failure to keep impeller bolt tight may result in damage to the engine, blower housing, impeller, or all of the above.

CHECK BEFORE EVERY USE!

ASSEMBLY INSTRUCTIONS

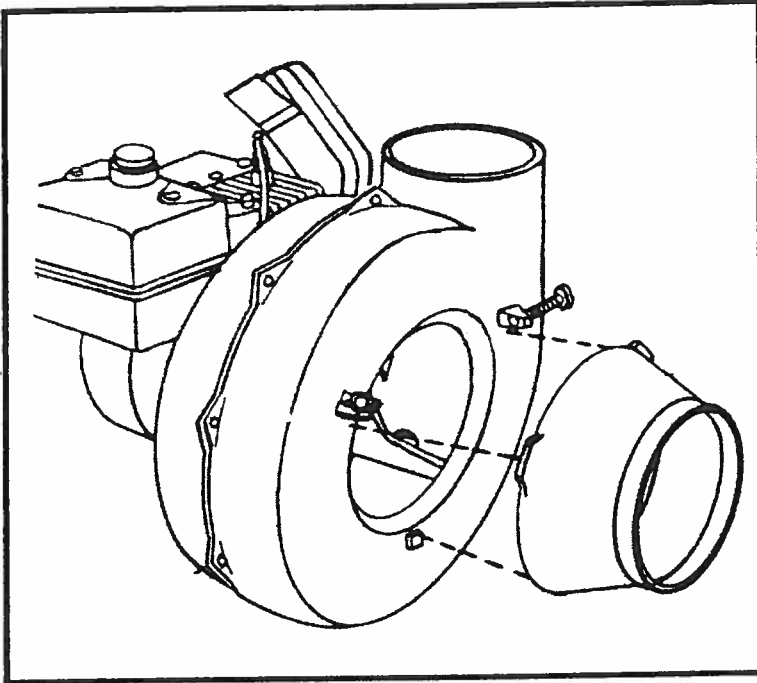

18. **Secure the blower cone's bottom edge on the raised tab with (2) 5/16"-18 x 2" all thread hex bolts.**

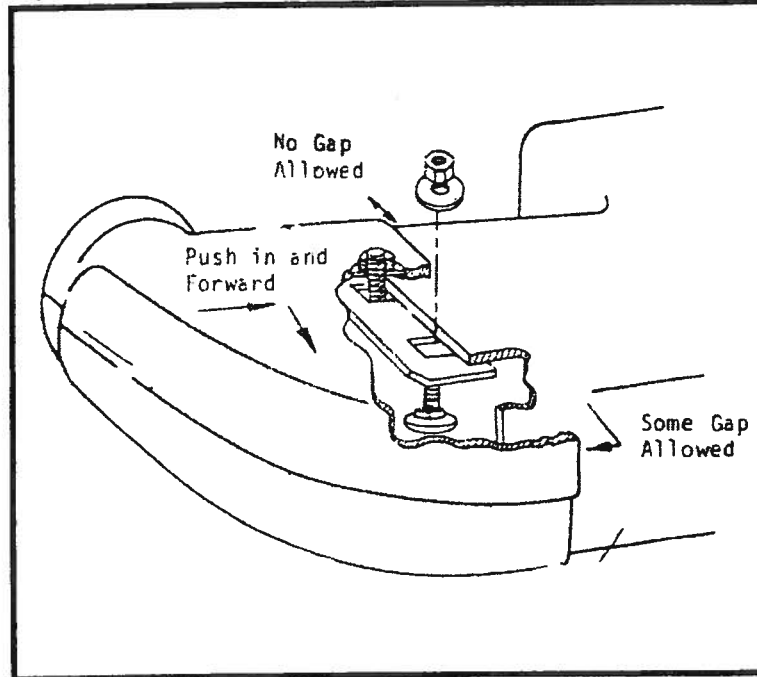

19. **Place the boot over the end of the mower deck. Tighten the nuts and bolts.**

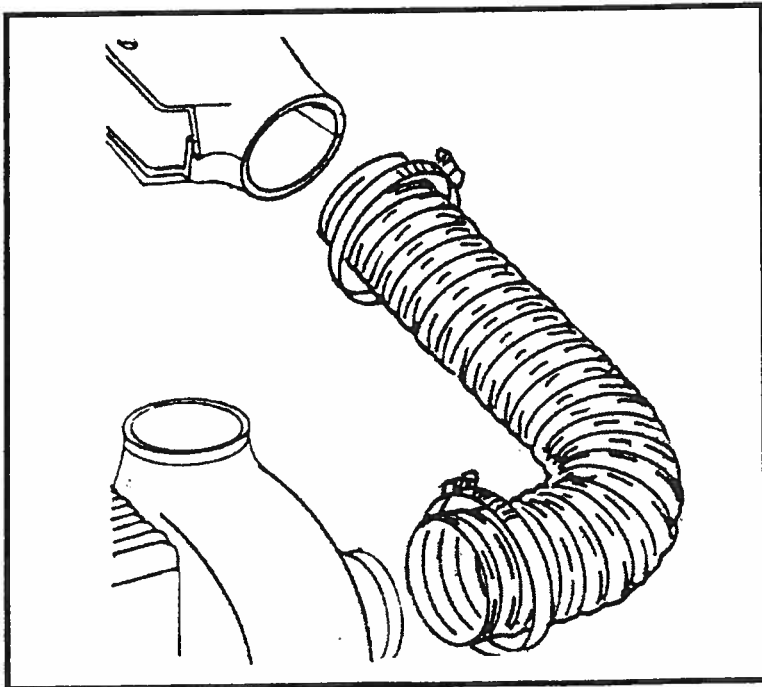

20. **Place the hose clamps over each end of the hose. Attach one end of the hose over the boot and tighten the hose clamp. Place the loose hose end on the blower cone and tighten the hose clamp.**