

LEAF BLOWER

USER MANUAL

SAFETY AND OPERATION INSTRUCTIONS

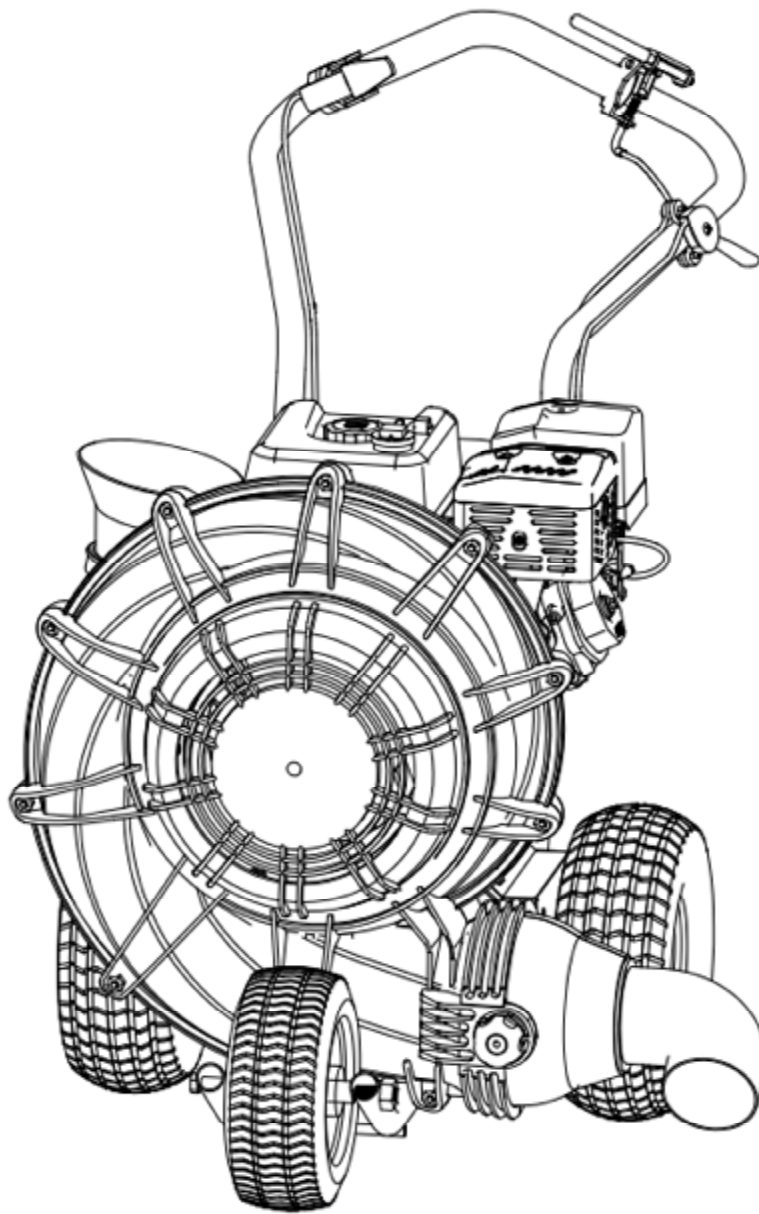

IMPORTANT: Read safety rules and instructions carefully before operating equipment.

Table of Contents

PART I: General Safety Rules.....	2
PART II: Familiar with the Leaf Blower.....	6
PART III: Operating the Leaf Blower.....	7
PART IV: Maintaining the Leaf Blower	10
PART V: Troubleshooting and Parts List	12

Conventions used in this manual

WARNING

This indicates a hazardous situation, which, if not avoided, could result in death or serious injury.

CAUTION

This indicates a hazardous situation, which, if not avoided, could result in minor or moderate injury.

NOTICE

This information is important in proper using of your machine. Failure to follow this instruction could result in damage to your machine or property.

Additional Information and Potential Changes

We reserve the right to discontinue, change, and improve its products at any time without notice or obligation to the purchaser. The descriptions and specifications contained in this manual were in effect at printing. Equipment described within this manual may be optional. Some illustrations may not be applicable to your machine. This manual provides complete operating and maintenance instructions that will help to maintain your Leaf Blower in top running order. Read this manual carefully before assembling, operating, or servicing your equipment.

PART I: General Safety Rules

Safety Labels Found on Your Unit



! WARNING

Read this Safety & Operating Instructions manual before you use the Leaf Blower. Become familiar with the operation and service recommendations to ensure the best performance of your machine.

Propose

! CAUTION

This machine is designed for cleaning outdoor surfaces, where the debris can be effectively blown into a consolidated area for convenient pickup and removal, and must not be used for

any other purpose. It should only be used by trained operators who are familiar with the content of this manual. It is potentially hazardous to fit or use any parts other than your dealer parts. The company disclaims all liability for the consequences of such use, which in addition voids the machine warranty.

Before using the Leaf Blower

NOTICE

- A. Operators must be fully trained before using this machine.
 - B. User Manual is read and understood.
 - C. All fasteners are checked for tightness.
 - D. Fire extinguisher is available on site.
-

When using the Leaf Blower

NOTICE

- A. Maintain strict discipline at all times and service machine at specified periods.
 - B. Note the wind direction to prevent debris from being blown into highway or where it could affect members of the public.
 - C. DO NOT put any part of your body into the discharge while the machine is running.
 - D. DO NOT operate the machine whilst under the influence of alcohol or drugs.
-

Protecting Yourself and Those Around You

WARNING

This is a high-powered machine, with moving parts operating with high energy. You must operate the machine safely. Unsafe operation can create a number of hazards for you, as well as anyone else in the nearby area. Always take the following precautions when using this machine:

- A. Keep in mind that the operator or user is responsible for accidents or hazards occurring to other people, their property, and themselves.
 - B. Always wear protective goggles or safety glasses while using the leaf blower to protect your eyes from possible thrown debris.
 - C. Wear shoes with non-slip treads when using your leaf blower. If you have safety shoes, we recommend wearing them. Do not use the machine while barefoot or wearing open sandals.
 - D. Keep bystanders at least 30 feet away from the wind direction at all times.
-

Safety for Children and Pets

WARNING

Tragic accidents can occur if the operator is not alert to the presence of children and pets. Children are often attracted to the machine and the chipping activity. Never assume that

children will remain where you last saw them. Always follow these precautions:

- A. Keep children and pets at least 30 feet from the wind direction and ensure they are under the watchful care of a responsible adult.
 - B. Never allow children to operate the leaf blower.
-

Safety with Gasoline - Powered Machines

WARNING

Gasoline is a highly flammable liquid. Gasoline also gives off flammable vapor that can be easily ignited and cause a fire or explosion. Never overlook the hazards of gasoline. Always follow these precautions:

- A. Never run the engine in an enclosed area or without proper ventilation as the exhaust from the engine contains carbon monoxide, which is an odorless, tasteless, and a deadly poisonous gas.
 - B. Store all fuel and oil in containers specifically designed and approved for this purpose and keep away from heat and open flame, and out of the reach of children.
 - C. Replace rubber fuel lines and grommets when worn or damaged and after 5 years of use.
 - D. Fill the gasoline tank outdoors with the engine off and allow the engine to cool completely. Don't handle gasoline if you or anyone nearby is smoking, or if you're near anything that could cause it to ignite or explode. Reinstall the fuel tank cap and fuel container cap securely.
 - E. If you spill gasoline, do not attempt to start the engine. Move the machine away from the area of the spill and avoid creating any source of ignition until the gas vapors have dissipated. Wipe up any spilled fuel to prevent a fire hazard and properly dispose of the waste.
 - F. Allow the engine to cool completely before storing in any enclosure. Never store a machine that has gas in the tank, or a fuel container, near an open flame or spark such as a water heater, space heater, clothes dryer or furnace.
 - G. Never make adjustments or repairs with the engine running. Shut down the engine, disconnect the spark plug wire, keeping it away from the spark plug to prevent accidental starting, wait 5 minutes before making adjustments or repairs.
 - H. Never tamper with the engine's governor setting. The governor controls the maximum safe operation speed and protects the engine. Over-speeding the engine is dangerous and will cause damage to the engine and to the other moving parts of the machine. If required, see your authorized dealer for engine governor adjustments.
 - I. Keep combustible substances away from the engine when it is hot.
 - J. Never cover the machine while the muffler is still hot.
 - K. Do not operate the engine with the air cleaner or the carburetor air intake cover removed. Removal of such parts could create a fire hazard. Do not use flammable solutions to clean the air filter.
 - L. The muffler and engine become very hot and can cause a severe burn; do not touch.
-

General Safety

WARNING

Operating this leaf blower safely is necessary to prevent or minimize the risk of death or serious injury. Always take the following precautions when operating:

- A. Your leaf blower is a powerful tool, not a plaything. Exercise extreme caution at all times.
 - B. Know how to stop the leaf blower quickly.
 - C. Never operate your unit on a slippery, wet, muddy, or icy surface. Exercise caution to avoid slipping or falling.
 - D. See manufacturer's instructions for proper operation and installation of accessories.
 - E. Never, under any conditions, remove, bend, cut, fit, weld, or otherwise alter standard parts on the leaf blower. This includes all shields and guards. Modifications to your machine could cause personal injuries and property damage and will invalidate your warranty.
 - F. If the machine start to make an unusual noise or vibrate, shut down the engine, disconnect the spark plug wire, keeping it away from the spark plug to prevent accidental starting, wait 5 minutes for engine to cool down, then inspect for damage. Vibration is generally a warning of trouble. Check damaged parts and clean, repair and/or replace as necessary.
 - G. Never tamper with safety devices. Check their proper operation regularly.
 - H. Before performing any maintenance or inspection procedure, shut down the engine, disconnect the spark plug wire keeping it away from the spark plug to prevent accidental starting, wait 5 minutes for machine to cool down.
 - I. Never allow people who are unfamiliar with these instructions to use the leaf blower. Allow only responsible individuals who are familiar with these rules of safe operation to use your machine.
 - J. While using, don't hurry or take things for granted. When in doubt about the equipment or your surroundings stop the machine and take time to look things over.
 - K. Never operate the machine when under the influence of alcohol, drugs, or medication.
 - L. Use the machine only in daylight.
 - M. Stay alert for hidden hazards or traffic.
 - N. Keep all nuts and bolts tight and keep the equipment in good operating condition.
-

A Note to All Users

List of warnings and cautions cannot be all-inclusive. If situations occur that are not covered by this manual, the operator must apply common sense and operate this LEAF BLOWER in a safe manner. Contact the dealers for assistance in your area.

PART II: Familiar with the Leaf Blower

It may be helpful to familiarize yourself with the controls and features of the Leaf Blower. If you have any question, please contact the dealers in your area.

TECHNICAL SPECIFICATIONS

	Recoil Start
Engine	13HP/13.5HP/15HP four strokes
Displacement	390cc/420cc
Power	Gasoline/petrol
Velocity	Just under 200mph
Fan	17" 16-blade Single Shot Composite
Discharge	5 inch
Front Wheel	10"x3" Pneumatic
Rear Wheels	13"x5" Pneumatic
Overall Length	58inch
Width	28.5inch
Weight	152LBS

Assembly

1. Follow the below figure, securely tighten the upper handle.
2. Connect spark plug wire.

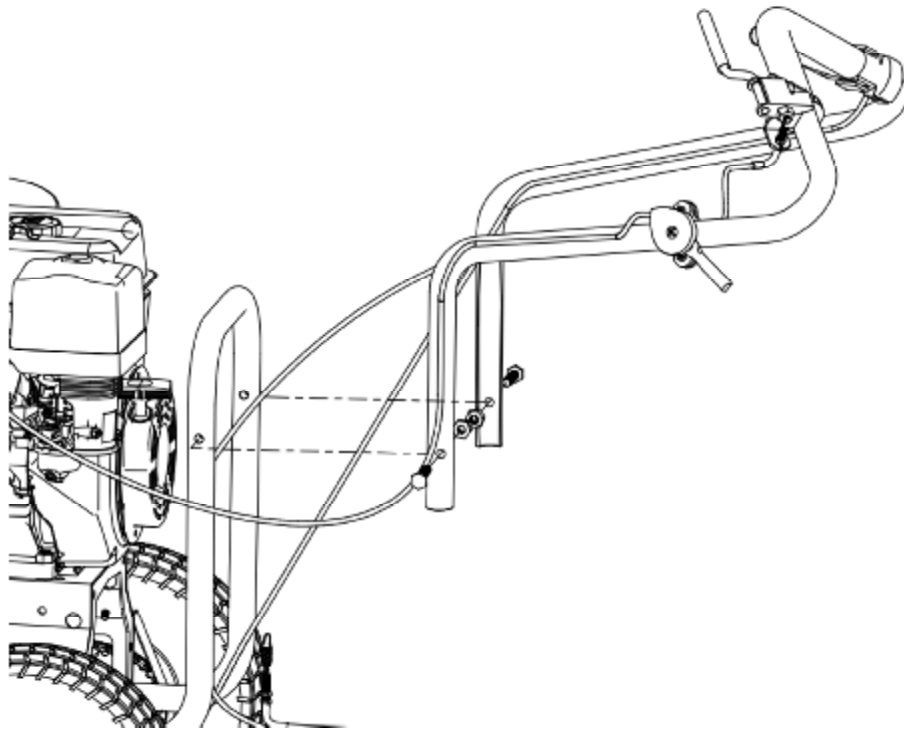

PART III: Operating the Leaf Blower

It may be helpful to better familiarize yourself with the features of your Leaf blower before beginning the steps outlined in this chapter.

WARNING

- A. Read and understand all instructions, safety precautions, and/or warnings listed in “PART I: General Safety Rules” before operating the Leaf Blower. If any doubt or question arises about the correct or safe method of performing anything found in this manual, please contact the dealers in your area.
 - B. Make sure that all operators of this equipment are trained in general machine use and safety.
 - C. Knowing the correct and incorrect methods of using leaf blower. Never using an incorrect or unsafe method.
 - D. Inspect machine work area and machine before operating.
 - E. **PUT OIL IN ENGINE BEFORE STARTING**
 - F. Do not operate if excessive vibration occurs. Shut engine off immediately and check for damaged or worn impeller, loose impeller bolt, loose engine or lodged foreign objects.
-

Starting

1. Position your leaf blower on flat, dry ground.
2. Make sure the fuel shut-off valve is in the “ON” position.
3. Move the choke control lever to the “CHOKE” position (should only be needed if the engine is cold).
4. Move the throttle control lever to the “FAST” position.
5. Recoil Start: Turn the Ignition Switch to the “On” position. Grasp the recoil starter handle and slowly pull until you feel resistance. Let the cord retract a little bit then pull the cord rapidly to start the engine. One or two pulls usually starts the engine.
6. Electric Start(if have): Turn and hold the Key in the start position until Engine starts then let the Key return to run position.
7. Move the choke control lever (if used for cold engine) slowly back to the “RUN” position when the engine is running well.
8. If the Leaf Blower has not been running (cold engine), warm up the engine by running the engine at half throttle for 3 to 4 minutes, then advance the engine throttle control to the maximum speed.

Stopping

1. Move the Throttle Lever to IDLE.
2. Recoil Start: Turn the Ignition Switch to the OFF position.
3. Electric Start: Turn the Key to the OFF position.

Blowing Operation

Your Leaf blower is equipped with an air director cone to allow the operator to direct the air stream up or down as required to assist in moving debris. This feature is extremely useful when debris has piled up to the point that it cannot be blown any farther. The air stream can be directed upward to blow the top of the debris pile over and allow the operator to continue moving more debris farther.

Adjusting Air Director

To adjust air direction, first loosen knob and then position air director cone to desired angle. When the cone is at a suitable position tighten knob to secure. **DO NOT** position director cone to where it will blow debris towards people, vehicles or other objects in vicinity. Flying debris may damage, harm, or cause injury to people or objects in air flow range.

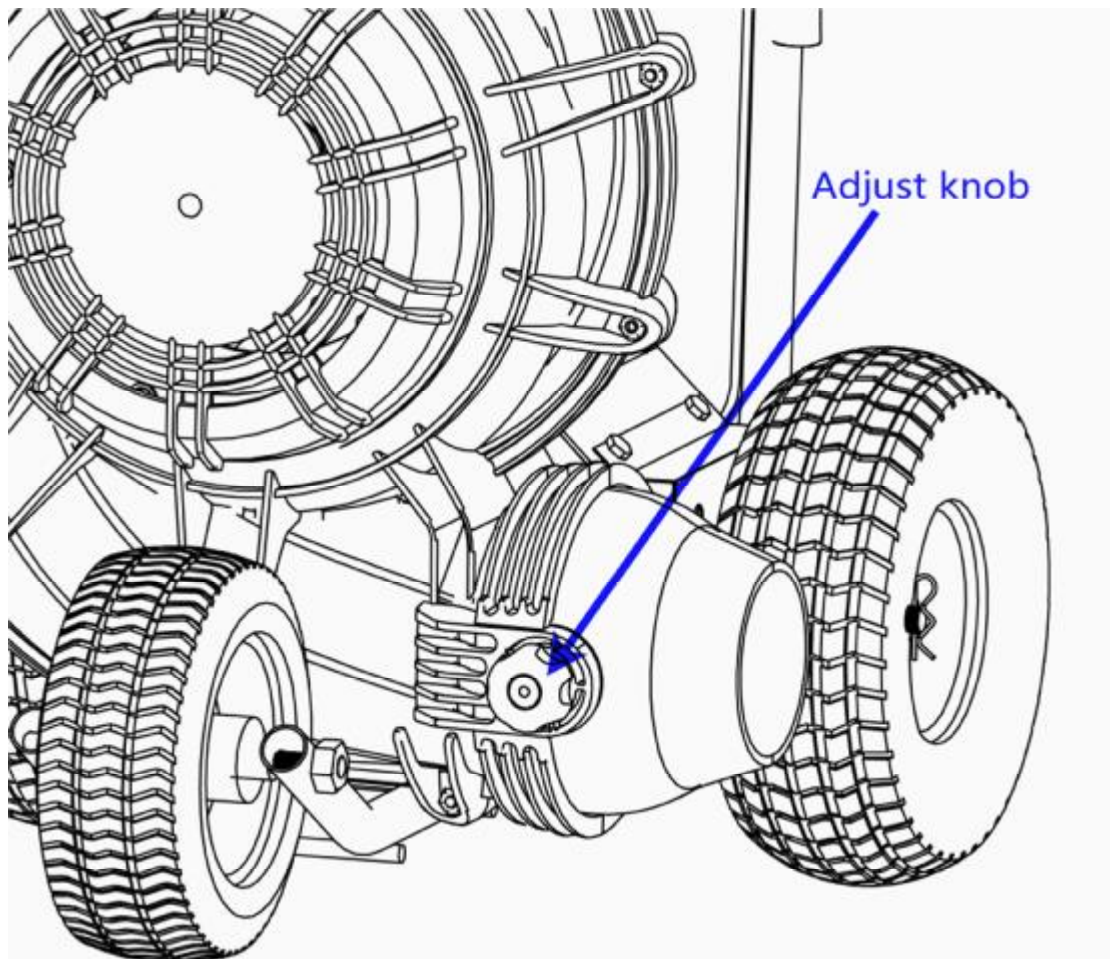

Front Diverter Positioning

The removable front diverter adapter can be slipped on to direct the air stream forward. First shut off engine, and then simply slide diverter onto cone. This option is extremely useful for cleaning out long cracks in pavement or for cleaning under bushes, building overhangs or along curbs.

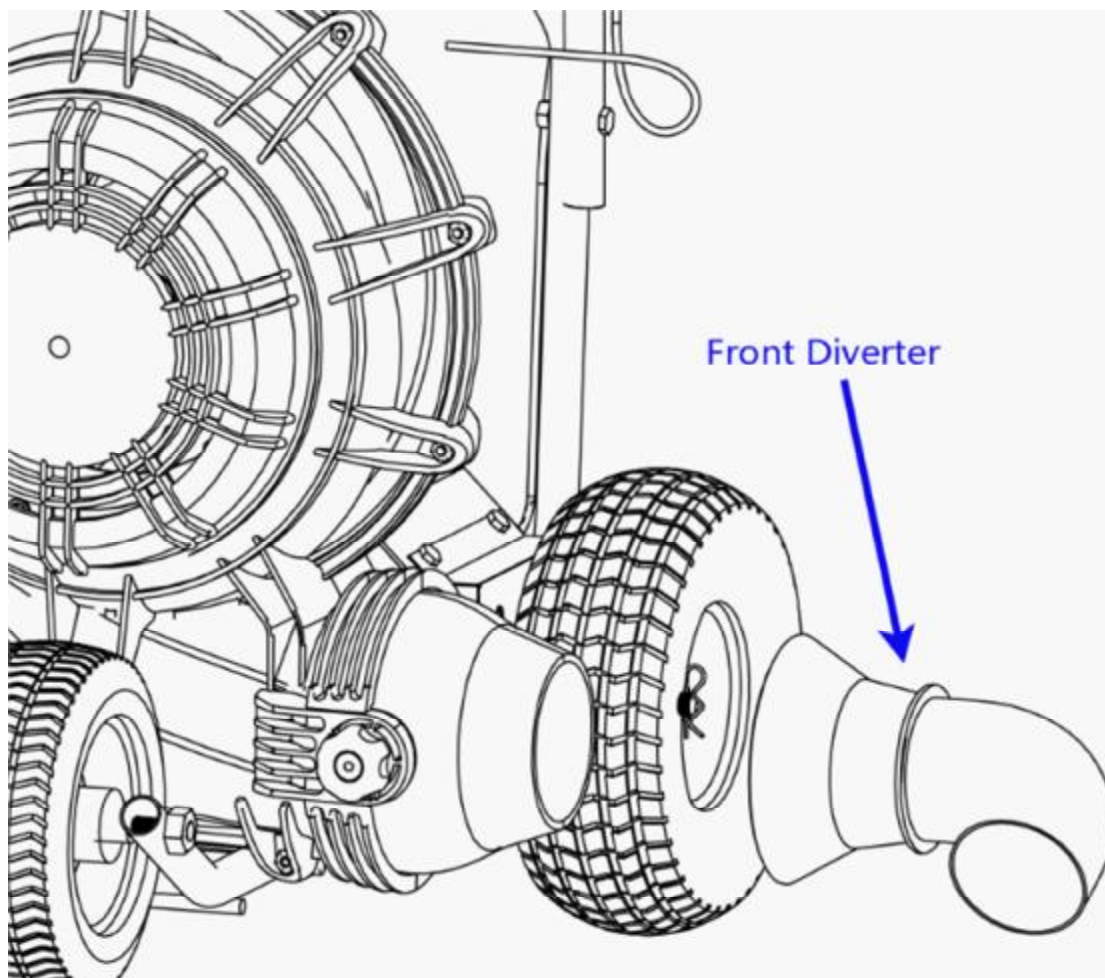

⚠ WARNING

Unit will be hard to handle and be pushed backward by the force of the air pushing against the unit. Keep hands on the unit at all times when using the front diverter.

PART IV: Maintaining the Leaf Blower

Regular maintenance is the way to ensure the best performance and long life of your machine. Please refer to this manual and the engine manufacturer's user manual for maintenance procedures.

WARNING

Before performing any maintenance procedure or inspection, stop the engine, wait five minutes to allow all parts to cool. Disconnect the spark plug wire, keeping it away from the spark plug. Disconnect the Battery Terminals (Electric start only).

Storage

WARNING

- a. Never store engine indoors or in enclosed poorly ventilated areas with fuel in tank, where fuel fumes may reach an open flame, spark or pilot light, as on a furnace, water heater, clothes dryer or other gas appliance. If engine is to be unused for 30 days or more, prepare as follows: Remove all gasoline from carburetor and fuel tank to prevent gum deposits from forming on these parts and causing possible malfunction of engine. Drain fuel outdoors, into an approved container, away from open flame. Be sure engine is cool. Do not smoke. Run engine until fuel tank is empty and engine runs out of gasoline.
 - b. Fuel stabilizer is an acceptable alternative for minimizing the formation of gum deposits during storage. Add stabilizer to gasoline in storage container or fuel tank. Follow stabilizer manufacturer's instructions to determine proper mix ratio. Run engine at least 10 minutes after adding stabilizer to allow it to reach carburetor.
-

Regular Maintenance Checklist

Procedure	Before Each Use	Every 3 Hours	Every 25 Hours	Every 100 Hours
Check engine oil level	Δ			
Check general equipment condition	Δ			
Check wedge for sharpness	Δ			
Grease surface of slide rail	Δ			
Check belts	Δ			
Grease rack and pinion		Δ		
Check tire pressure			Δ	
Clean engine exterior and cooling			Δ	
Change Engine Oil	First time 5hours		Δ	
Replace air filter			Δ	
Replace spark plug				Δ

Engine Service

Refer to the engine manufacturer's user manual for engine maintenance.

Handling and Transportation

Notice

1. Using two people to lift machine is recommended. Lift holding the handle and handle brace. Secure in place during transportation.
2. Do not use the front grill as an anchor point when securing the unit for transport.
3. Never lift the machine while the engine is running.

PART V: Troubleshooting and Parts List

Most problems are easy to fix. Consult the Troubleshooting Table below for common problems and their solutions. If you continue to experience problems, contact the dealers in your area.

WARNING

Before performing any maintenance procedure or inspection, stop the engine, wait five minutes to allow all parts to cool. Disconnect the spark plug wire, keeping it away from the spark plug.

Troubleshooting Table

SYMPTOM	POSSIBLE CAUSE
<p><i>The engine won't start.</i></p> <p><i>(Please refer to the engine user manual for engine-specific procedures.)</i></p>	<ul style="list-style-type: none"> ∅ <i>Is the ignition switch in the "ON" position?</i> ∅ <i>Is the fuel shut-off valve on?</i> ∅ <i>Are you using fresh, clean gas? If the gas is old, change it. Use a fuel stabilizer if you keep gas longer than 30 days.</i> ∅ <i>Is the spark plug clean? If the spark plug is dirty or cracked, change it. If it's oily, leave it out, hold a rag over the plug hole and pull the recoil cord several times to blow out any oil in the cylinder, then wipe off the plug and reinsert it.</i>
<p><i>The engine lacks power or is not running smoothly.</i></p> <p><i>(Please refer to the engine user manual for engine-specific procedures.)</i></p>	<ul style="list-style-type: none"> ∅ <i>Check that the Throttle Lever is in the "Run" position.</i> ∅ <i>Is the air filter clean? If it's dirty, change it following the procedure in the engine manufacturer's owner's manual.</i> ∅ <i>Is the spark plug clean? If it's fouled or cracked, change it. If it's oily, leave it out, hold a rag over the plug hole and pull your recoil cord several times to blow out any oil in the cylinder, then wipe off the plug and reinsert it.</i> ∅ <i>Are you using fresh, clean unleaded gas? If it's old, change it. Use a fuel stabilizer if you keep gas longer than 30 days.</i> ∅ <i>Does your engine have the right amount of clean oil? If it's dirty, change it following the procedure in the engine manufacturer's owner's manual.</i> ∅ <i>Check the oil level and adjust as needed.</i>
<p><i>Engine smokes.</i></p> <p><i>(Please refer to the engine user manual for engine-specific procedures.)</i></p>	<ul style="list-style-type: none"> ∅ <i>Check the oil level and adjust as needed.</i> ∅ <i>Check the air filter and clean or replace if needed.</i> ∅ <i>You may be using the wrong oil—too light for the temperature. Refer to your Engine Owner's Manual for detailed information.</i> ∅ <i>Clean the cooling fins if they're dirty.</i>

<i>excessive vibration</i>	<ul style="list-style-type: none">Ø <i>Check engine</i>Ø <i>Check for damaged or worn impeller, loose impeller bolt, loose impeller key, loose engine or lodged foreign objects</i>
----------------------------	--

Explosion View and Parts List

Ref.No.	Description	Ref.No.	Description
1	Fan cover	38	F203 lozenge bearing
2	Adjust knob	39	Gear-box
3	Φ 44*Φ 9*Φ 4 washer	40	M8*20 hex bolt
4	Front shell	41	Φ 8 washer
5	Wind discharge	42	M6*30 socket head bolt
6	M8*25 bolt	43	Chain cover(Left)
7	Φ 12*130*1.5 spring	44	M8*105 hex bolt
8	M8*50 bolt	45	Φ 25*Φ 15*15 spacer
9	M10*45 hex bolt	46	61800 bearing
10	Diverter	47	tightener sheave
11	U-pin	48	M8*20 hex bolt
12	M18 open nut	49	Direction wire fitting
13	Rear wheel 13*5-6	50	Wind direction board
14	Small Chain wheel	51	M6*65 socket head bolt
15	Big chain wheel	52	ST5*25 tap bolt
16	Chain	53	M8 lock nut
17	M16*260 bolt	54	A737 belt
18	Front wheel 4.1/3.5-4	55	Engine
19	Φ 25*Φ 18*30 spacer	56	Φ 35*Φ 25*13 spacer
20	M16 lock nut	57	Pulley
21	Main frame	58	Belt cover
22	M10*30 bolt	59	Switch clip(UPPER)
23	Chain cover(Right)	60	Diverter shelf
24	M10*55 hex bolt	61	Switch clip(DOWN)
25	Throttle	62	Fan fitting
26	Throttle fitting	63	M6*35 socket head bolt
27	Direction switch fitting	64	Rear shell
28	Handle	65	Rear shell fitting
29	M10 nut	66	M8*55 socket head bolt
30	Impel switch	67	M6*20 socket head bolt
31	Impel switch fitting	68	Fan pipe spreader
32	M10*70 hex bolt	69	Fan
33	Φ 40*Φ 32*500 cover	70	Φ 30*Φ 8.2*3 washer
34	Impel handle cover	71	M8*85 socket head bolt
35	Direction switch handle	72	M6*20 socket head bolt
36	Handle fitting	73	M6 nut
37	M10*50 hex bolt		

